

Welborne Associates

July Newsletter 1999

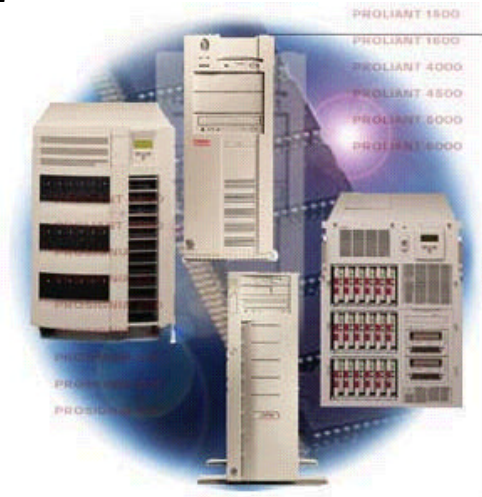

Click on any item in the Table of Contents list to make your reading selection.
The graphic above is a hyperlink to the Compaq Enterprise Server site.
Any blue text in the body of this newsletter is clickable and is a hyperlink to follow to learn more about the subject in the article.

IN THIS ISSUE

We're focusing on Compaq Enterprise level server features for ease of management and non-stop 24 X 7 operations.

TABLE OF CONTENTS

Click on any title to go to that page, or just scroll through.

- Compaq Directions
- Remote Insight/ PCI
- SmartStart
- Insight Manager
- Insight Manager XE
- Decision Matrix for Choosing ProLiant Servers
- Did You Know?
 - Compaq and Steppenwolf
 - Compaq Helps Missing Children
- Welborne Associates Features of the month
 - We're Now Compaq Authorized Enterprise Reseller
 - Special Pricing on Servers!

Compaq Directions



The following is an excerpt from an article titled Compaq: The New World of Computing, in DM Review, May 1999. You can access the entire article by clicking on <http://www.datawarehouse.com>. It helps to explain why the “New Compaq” has been so successful, and why IT professionals choose Compaq.

The interview of John Nicholson, vice president of Compaq’s Database and Business Intelligence business Unit, Enterprise Solutions Division, reveals the directions Compaq is taking to solidify their position as the “New Compaq,” a solutions-oriented company with a strong, clear commitment to the business intelligence marketplace. With the acquisition of Tandem in 1997, and Digital in 1998, Compaq is now the second largest computer company in the world, and the leading developer of enterprise computing solutions. “Compaq’s mission in business intelligence is to be the leader in providing industry-standard solutions. We want to be an agent of change. That’s pretty much what differentiates us from the competition.” Nichols adds.

“The value proposition that we take is that we want to deliver solutions that ensure our customers a fast route to success, with less risk and lowest total cost. I’ve never met a customer yet that didn’t want those things. My experience with customers is that they want to buy solutions to identified problems or business needs. They do not want to buy something that adds complexity. And I think the technology industry in general has too often been guilty of that. The price that people have to pay day in and day out to operate solutions based on technology is, in our view, too high. We have to reduce that burden.”

“I think it’s incumbent on any company that wants to operate globally to realize that one size does not fit all. The challenge for me, individually and corporately, is to make sure that the building blocks of value that we provide are able to be reassembled into something that looks right, feels right and provides competitive advantage for a customer in the British market, the French market, the German market, in Singapore and in Australia as well as in North America.”

Nicholson’s hobby is climbing Scotland’s Monro listed mountain peaks, and expresses his business philosophy in the same kind of elevated terms. “Compaq’s climb to the summit of the “New World of Computing” has been accomplished through innovative business intelligence solutions that address the full range of customer needs.”

Did you know that?—According to IDC, Compaq accounted for over 34% of the total Intel-based server revenue in the second quarter of 1998. This is nearly as much as Dell, HP and IBM combined.

In September of 1998, Compaq shipped its two-millionth server. It took seven years to ship the first million, but only two additional years to ship the second million. None of the three competitors listed above has topped the one million mark to date.

Compaq Remote Insight PCI

Today's networked systems are some of the most complex computing environments ever constructed, with network resources distributed across many locations. Does the business-critical nature of the applications on your networks require predictable, optimal performance? Are you constantly challenged to maximize network up-time, availability and user access? Do you need to isolate the problem causes and respond quickly? Here's help!

By providing tools that improve manageability and increase server availability across the enterprise, **Remote Insight** provides a robust fail-safe solution for server management in this distributed environment. **Remote Insight** operation is fully independent from the host hardware (self-contained processor, memory, battery, modem), host operation system and network connection. This high level of independence ensures that regardless of server state, administrators have access to the server and will be immediately notified of critical server events, including server power failures.

- Full SNMP access with **Compaq Insight Manager** Remote Reboot allows the remote administrator to reboot the server on demand.
- **Remote Insight** Console provides a remote connection to managed servers.
- **Remote Insight** provides Remote Graphical Console capabilities for Windows NT servers utilizing standard graphics based terminal emulation software tools such as Compaq Carbon Copy 32 and Symantec PCAnywhere 32.
- Reset and Failure Sequence Replay captures and stores server video text to assist in locating startup problems and causes of failure.
- Browser support - Enables the **Remote Insight** Board to be accessed via Netscape Navigator or Microsoft Internet Explorer to perform management functions.

Prices-\$709* (LAN only), \$886* (LAN+Modem), \$886* (LAN+Serial)

To find out more, click on:

<http://www.compaq.com/products/servers/management/crim-description.html>

To order your Compaq Remote Insight PCI, Call , E-mail, or Fax Penny with a Purchase Order Number. Call 800-3584 or Fax 219-879-0614 or email Penny.Rush@welborne.com

Compaq SmartStart

Compaq SmartStart for Servers is an integration tool that configures Compaq hardware, loads optimized drivers and assists with software installation. It also provides functionality for integrating operating system software on Compaq servers to achieve optimum reliability and performance. **Compaq SmartStart Ships Standard-at no extra charge-with all Compaq Servers.**

Integration Management features extend the benefits of **SmartStart** and facilitate consistency and reliability of server deployment and maintenance. **SmartStart** for Servers is just part of Compaq's continuing commitment to provide well-integrated, top-performing server solutions.

This is right off of the Installation preview-Advantages of using Smartstart

- Auto-detects and configures hardware
- Helps you setup your server quickly and easily
- Loads Compaq optimized drivers
- Assists in installing the operating system
- Delivers Compaq integration expertise and experience

<http://www.compaq.com/products/servers/smartstart/index.html>

Compaq Insight Manager

Compaq **Insight Manager**, the comprehensive management tool that monitors the operation of Compaq servers, workstations and clients, is designed to be a key component in the networked systems management environment. **Insight Manager ships standard-at no extra charge-with all Compaq servers.**

The strength of Compaq **Insight Manager** lies in its ability to give system administrators real control through its intuitive visual interface, comprehensive fault and configuration management, and industry-leading remote management.



This powerful tool is an integral part of our enterprise computing solutions, which bring in our industry-leading technology, commitment to industry standards, unique manageability features and global service and support to meet today's business needs. Compaq **Insight Manager** adds OS management for Microsoft Windows NT environment to its superior hardware availability management by integrating key technology from BMC Software into the Compaq Server Management Agent for Windows NT.

Compaq provides these components from BMC Software to enhance the quality and detail of information reported by the Compaq Server Management Agent. The parameters use default settings to provide alerts when certain operational and performance thresholds are reached so they are instantly usable. These thresholds have been set by Compaq's engineering teams based on best practices for Windows NT management.

By being able to quickly determine if an event is caused by hardware or software, users of the new Windows NT monitoring capability will benefit from faster determination of the root cause of system and application faults. Another benefit is the easier add - in of application management modules from BMC. Customers will also benefit from proactive performance analysis and tuning of the integrated platform and application environments. Compaq **Insight Manager** now supports Alpha servers running Compaq Tru64 UNIX V4.0F Operating System

Compaq has extended its web - based management technology to support Alpha servers running Compaq True64 UNIX operating system. This step takes Compaq further towards a unified management architecture. Reduces system management costs and decreases server downtime. Volume License Agreement has been discontinued. Now provides support for Digital (Intel) Servers running NT and SCO and (Alpha) Servers running NT. Support for Novell NetWare 5.0 and UnixWare 7. For more about Insight Manager click on: <http://www.compaq.com/products/servers/management/insight423-description.html>

Did You Know?

Compaq has a commitment to helping its local and national communities. John Nicholson, Vice president of Compaq's Database and Business Intelligence Business Unit, enterprise Solutions Division, commented that, "Compaq recently donated about \$340,000 of computer equipment to the National Center for Missing and Exploited children which was a long term Digital-supported project. In the time that we've been working with the Center, it has helped approximately 43,000 children."

Compaq Insight Manager XE

Compaq **Insight Manager XE**, a Web-based Enterprise Management (WBEM) application, will transform the management of standards-based distributed computing environments. By enabling browser access to both managed devices and the management application, Compaq **Insight Manager XE** provides management of devices and groups of devices anywhere, anytime.

Pre-configured management application and management agents provide immediate use of application. Browser accessed management application and agents request authorization of user at login allow accessibility to management information anywhere, anytime, securely. Automatic discovery and identification of Compaq and non-Compaq devices. Based on industry standards - consistent management of DMI V2, SNMP and HTTP devices. Predictive fault management and Pre-Failure warranty for disks, memory and CPU. More about Compaq **Insight Manager XE** at:

<http://www.compaq.com/products/servers/management/cim-xe-description.html>

Compaq Insight Manager XE will be shipped by request to Compaq users. Customers simply need to fill out a request form on the Compaq website. Please visit <http://www.compaq.com/products/servers/management/form.html> to submit a request form.

Compaq Insight Manager compared with Compaq Insight Manager XE

	Compaq Insight Manager	Compaq Insight Manager XE
Automatic Discovery	IP and IPX-servers only	IP and IPX-all devices
Client Discovery	Logon Script	Automatic discovery without logon script
Protocol Support	SNMP	SNMP, CMI, HTTP
Device Identification	Compaq only server, workstations, desktops, portables	Compaq devices, and third party DMI v2 and SNMB MIB-2 devices.
Database	Paradox (bundled)	Microsoft SQL Server (available separately)
Data Collection	Compaq servers/workstations extensive not customizable	All devices, data defines by Compaq, no automatic data collection
Client Access	Logon server	All devices are available at device list
Notification	Pager, email	Email, Execution of application/script, paging application
Web Access	Launches browser for device list, alarm log, web-enhanced Agent	Systems Manager, CPQ 4.x Agents, Proxy for Compaq 3.x Agents and third party DMI v2.0 & SNMP MIB2
Security	SNMP	User Authorization and SNMP
Version Control	Yes	Future add-in application
Integration Server Maintenance	Yes	Future add-in application
Reports	Yes, also able to export data to create custom reports	Database schema published to create custom reports

Confused about which server is right for your needs? This might help.

Decision Matrix for Choosing ProLiant Servers					
PRODUCT	Primary Controller (standard w/ system)	Standard Drive Cage	Wide Ultra SCSI-3 Hot Plug Drives	Ultra2 Hot Plug Drives	Optional Drive Cages
PL800 6/350/400/450/500	WU	NHP	4 x 1.6" or 4 x 1"	4 x 1" ¹	
			1. Requires optional Ultra 2 cable - #104936-B21		
PL1600 6/400/450	WU	WU	5x1"		Ultra2 (6x1") 82159-B21
PL1600 6/500	WU	Ultra2		6x1"	WU (5x1") 271912-B21
PL1850R 6/400/450	WU	WU	3x1"		Ultra2 382160-B21 (4x1"), U2 388255-B21 (2x1" center cage)
PL1850R 6/500	WU	Ultra2		4x1"	WU (3x1") 103357-B21, Ultra2 (2x1" center drive cage) 388255- B21
PL3000 6/333	WU	WU	6x1.6", 7x1"(simplex) or 8x1" (duplex)		Ultra2 (10x1") 382157-B21
PL3000 6/400/450/500	WU	WU	6x1.6", 7x1"(simplex)		Ultra2 (10x1") 382157-B21, WU (8x1" Duplex cage) 328073-B21
PL3000 6/500 Model 1S	Smart Array 3200	Ultra2		10x1"	WU (6x1.6" or 7x1") 328073-B21
PL5500 Xeon 400/450	WU	WU	7x1" or 6x1.6"		Ultra2 (10x1") 382157-B21 WU (8x1" Duplex cage) 328073-B21
PL5500 Xeon 500 (Ultra2 Models)	Dual Channel Ultra2	Ultra2		10x1"	WU (7x1" or 6x1.6") 328073-B21
PL5500 Xeon 500 (Wide-Ultra Mod- els)	WU	WU	7x1" or 6x1.6"		Ultra2 (10x1") 382157-B21 WU (8x1" Duplex cage) 328073-B21
PL6000 Xeon 400/450/ 500	WU on 1P systems 3100ES on 2P systems	WU	6x1" or 4x1.6"		Up to two additional WU cages (total 18x1" or 12x1.6") 273314-B21
PL6400R Xeon 500	WU	Ultra2		4x1"	
PL6500 Xeon 400/450/500	WU	WU	7x1" or 5x1.6"		Ultra2 (9x1") 382158-B21
PL7000 Xeon 400/450/500	Smart Array 3100ES	WU	18x1" or 12x1.6"		

WU = Wide Ultra SCSI-3

Welborne Associates Awarded CAER Status

We are proud to announce that Welborne Associates has achieved the status of Compaq Authorized Enterprise Reseller. This certification qualifies the company to sell and support the high end, massive computing systems necessary for non-stop, 24 hour a day, mission critical operations and e-business. In addition, we've been awarded SMB Reseller Status, and remain committed to providing comprehensive and effective support before and after the sale.

Compaq is severely limiting the number of their reseller partners lately and only awards this status to extremely well qualified organizations.

Company President Jim Welborne has more than 30 years in the computer business. Welborne Associates provides network and migration path consulting for businesses, manufacturers, major teaching hospitals and newspapers.

For your convenience, you can now order servers and other Intel based systems 24 hours a day, directly from Compaq by visiting our site at: <http://www.welborne.com>. If you choose this option you will be billed directly from Compaq. Contact us as usual for software, services and support for these products.

We are approved to sell and support:

Complex Alpha Tru64 UNIX/Open VMS/NT Servers.
Mid-Range Alpha Tru64 UNIX/Open VMS/NT Servers
and Tru64 UNIX/Open VMS Workstations
throughout the Midwest.

Did You Know?

Steppenwolf sings Compaq's praises. Legendary rock band Steppenwolf uses Compaq technology in the studio and on the road.

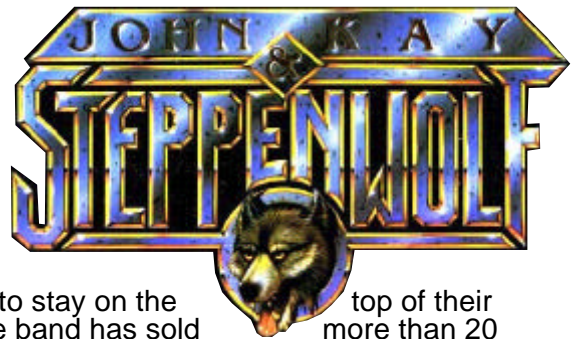

Mixing creativity and technology enables Steppenwolf to stay on the top of their musical form and the latest marketing techniques. The band has sold more than 20 million albums, CDs, and cassette tapes worldwide and has songs licensed for use in 37 motion pictures and 36 TV programs. The popular creators of hits such as "Magic Carpet Ride" and "Born to be Wild" use Compaq equipment to run MIDI (musical instruments digital interface), manage email, and update the band's Web site, <http://www.steppenwolf.com>, merchandise catalogue, <http://store.steppenwolf.com> and more.

According to keyboard player Michael Wilk, the band first bought Compaq computers in the early '80s to stand in for some musicians during songwriting sessions. They also bought laptops early on and currently use **Compaq Presario PCs** for email, spreadsheets, and other tasks. A **Compaq DeskPro 2000** records digital audio in the studio, and a new **450MHz Presario 5630** runs the band's Web site. Wilk uses the system to manage a database for the more than 30,000 merchandise catalogs the band has sent out, and to create "The Howl," their quarterly newsletter.

The **Presario 5360** now accompanies the band when they're on the road. They run it off a generator in their tour bus, offload the completed daily computing chores onto one of their **Compaq Presario 1080** laptops, and then take the lightweight gear into the hotel for Internet access.

Wilk commented, "The computers never missed a beat, didn't ask for money and never complained." What more could you ask from a roadie?

It's Time to Upgrade!

Buy an eligible ProLiant 3000
and receive a second processor at 75% off! *

WHAT'S NEW

- Intel Pentium® III 550-MHz Processor

AT A GLANCE

- Highly Parallel System Architecture for improved system bandwidth
- Intel Pentium III 550-MHz or 500-MHz processor (dual processor capability)
- 512-KB level 2 writeback cache per processor
- 100-MHz GTL Bus Design
- ECC-protected memory bus and cache
- 128-MB 100-MHz SDRAM (Model 1) or 256-MB 100-MHz SDRAM (Model Array) memory expandable to 4 GB
- Five PCI and three shared PCI/ISA slots (eight total slots)
- Internal mass storage capacity up to 218.4 GB (Ultra2 drive cage, 182 GB hot pluggable with ten 1" 18.2 GB Wide Ultra2 SCSI drives)
- Internal mass storage capacity up to 254.8 GB (Optional Simplex or Duplex drive cage, 218.4 GB hot pluggable with six 1.6" 36.4 GB Wide-Ultra SCSI-3 drives)
- Compaq NC3120 10/100 TX PCI UTP Controller (in a slot)
- Integrated Dual Channel Wide-Ultra SCSI-3 Adapter (Model 1)
- Smart Array 3200 Controller in PCI slot (Model Array)
- Wide-Ultra SCSI-3 Drive Cage standard in Model 1
- Wide Ultra2 SCSI Drive Cage standard in Model Array
- Integrated Remote Console and Automatic Server Recovery-2 (ASR-2)
- 750/500-Watt Hot Pluggable Power Supply with optional Hot Plug Redundant Power Supply (RPS)
- Integrated Management Display (IMD) (optional for Model 1)
- Compaq Insight Manager and SmartStart
- Protected by a three-year, on-site limited warranty and extended Pre-Failure Warranty which covers Intel Pentium III processors, memory and disk drives, as well as a wide range of Compaq Services

Receive a rebate for eligible Compaq ProLiant 3000 and eligible second processor sold and shipped together during the promotional period. Buy the second processor at 75% off if purchased by July 31, 1999.

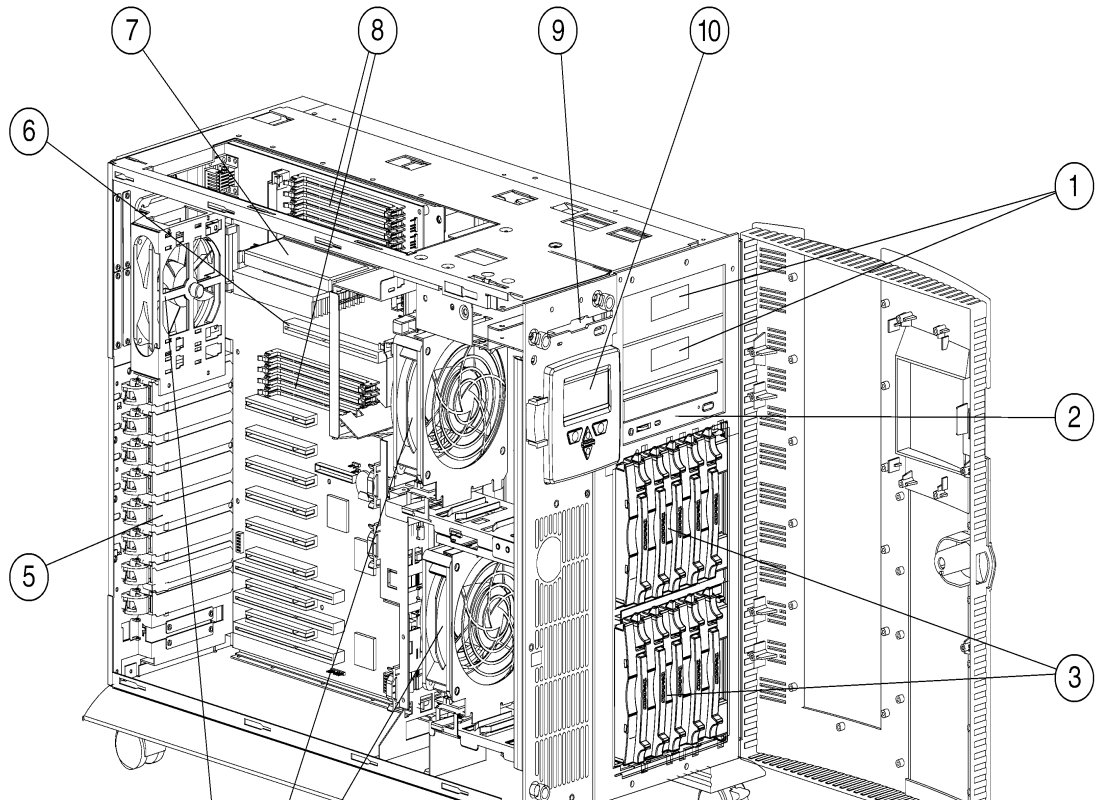

- 5.25-Inch Removable Media Bays
32X Max² IDE CD-ROM
Hot Plug Drive Cage (Wide Ultra2 or Wide-Ultra SCSI-3) Wide Ultra2 Drive cage shown
- Fans (Optional Redundant Fans)
- Eight total slots (5 PCI, 3 Shared PCI/ISA)
- Processor Slot Number 2
- Intel Pentium III Processor
- System Board DIMM Memory Sockets
3.5-Inch Diskette Drive
Integrated Management Display (IMD) (Optional for Model 1)

Eligible Server Part #	Server Description	Eligible second processor for 75% off	Rebate Amount
179740-001	ProLiant 3000 6/333-512KB	(333555-B21) PL3000 6/333 512K processor option kit	\$600
179750-001	ProLiant 3000R 6/333-512KB	(333555-B21) PL3000 6/333 512K processor option kit	\$600
179700-001	ProLiant 3000 6/400-512KB	(313612-B21) PL3000 6/400 512K processor option kit	\$712
179710-001	ProLiant 3000R 6/400-512KB	(313612-B21) PL3000 6/400 512K processor option kit	\$712

* Effective through July 31, 1999, or while supplies last. Certain restrictions and exclusions apply. Call Welborne Associates for complete details.

To order, Call , E-mail, or Fax Penny with a Purchase Order Number.
Call 800-3584 or Fax 219-879-0614 or email Penny.Rush@welborne.com